

## “4X4 NEZ CHAMPIONSHIP 2011”

### Regulations

#### Chapter 1. General rules.

- 1.1. LAF Trophy-raid committee, LASF 4x4 committee, EAU 4x4 Off-road committee - Estonia and RAF 4x4 committee – Russia announce the “4x4 NEZ CHAMPIONSHIP” series, hereinafter called NEZ CHAMPIONSHIP.
- 1.2. Normative documentation of the NEZ CHAMPIONSHIP:
  - NEZ CHAMPIONSHIP Official regulations
  - Organizing regulations of Trophy raid NEZ event
- 1.3. NEZ CHAMPIONSHIP series will take place in:
  1. Latvia 1-3 April - Kurland trophy 2011
  2. Lithuania 30 september-2 October – Gladiatorai 2011
  3. Estonia 18-20 November A.Sults Memorial 2011
- 1.4. Series regulations
  - 1.4.1 It is mandatory to print on the front cover of event regulations:
    - Championship logo
    - Organisers logo
    - Type, name, status and date of the race
  - 1.4.2 Regulations of the race are developed by the Organiser based on standard regulations.
  - 1.4.3 All additions to the standard regulations are to be marked in *Italic type* in regulations. All specific rules or technical requirements that contradict standard regulations are to be marked in *Italic type* in the regulations of the current race.
- 1.5. Officials of the race:
  - Sports commissar
  - International commissar
  - Technical commissar
  - Organizer of the race
- 1.6. Regulations must be published at least one month before the entry submission time limit ends, on leading 4x4 websites of Latvia, Lithuania, Estonia, Finland and Russia.

- 1.7. Once the entry submission has began no changes are allowed to the regulations, except changing the officials of the race, changes that are accepted by all those who have submitted the entries and changes made by Technical commissar due to force majeure conditions or due to the safety issues.
- 1.8. The sports commissar must be presented with the safety plan before the beginning of the race.
- 1.9. To include a traditional race in to the calendar of the next year's NEZ CHAMPIONSHIP series an application must be submitted (trofireidi@inbox.lv) till 1<sup>st</sup> of September 2011.

## Chapter 2. Participants

- 2.1. In 2011 NEZ CHAMPIONSHIP teams collect points during all the series of the NEZ CHAMPIONSHIP.
- 2.2. Entry submission starts at the moment when the regulations are published and ends 3 days before the beginning of the race.
  - 2.2.1 All participants receive points during the 2011 NEZ CHAMPIONSHIP. A team consists of 2-3 participants (2-4 for TR1 category), from whom at least one must be a driver. All the team members who have driver's licences have the right to drive the car during the race.
  - 2.2.2 Participants have to present the Trophy raid licence given to him by National federation, to be able to participate in the NEZ CHAMPIONSHIP.
- 2.3. Vehicle categories of the NEZ CHAMPIONSHIP:
  - First category – automobiles that correspond to TR1 technical specifications
  - Second category – automobiles that correspond to TR2 technical specifications
  - Third category – automobiles that correspond to TR3 technical specifications
  - Fourth category – automobiles that correspond to OPEN technical specifications.

## Chapter 3. Automobile

Gross vehicle weight must not exceed 3,5 tons. The vehicles must be in compliance with international convention on road traffic safety.

- 3.1. Preparation of the automobile should be in compliance with technical specifications of the corresponding category of the vehicle.
- 3.2. Automobiles are divided in following categories:

**TR1:** these basically are conventional cars with very few changes which correspond to TR1 technical specifications.

**TR2:** these are specially prepared conventional cars in compliance with TR2 technical regulations.

**OPEN:** conventional cars with more allowed changes which correspond to OPEN Technical specifications.

**TR3:** automobiles- prototypes

These cars have undergone some major reconstructions they basically have newly created original constructions that are in compliance with TR3 technical specifications.

- 3.2. Until the administrated check of the automobile by the technical commissar the participants have the right to change their current vehicle to another vehicle of the same category.
- 3.4. If during the technical commission the technical commissar detects that the vehicle does not correspond to the given category he has the right either to put the vehicle in the appropriate category or not to allow the team to participate in the race in which case the team's entry fee will not be refundable.

#### Chapter 4. Entries.

- 4.1. Anyone willing to participate in the NEZ CHAMPIONSHIP must send a filled out entry to the secretariat. The entry must contain following information:
  - Each participants Name, Surname, birth date, citizenship, address, phone number and drivers licence number.
  - Description of the vehicle
  - Sample of the entry form is annex 2 to these regulations
  -
- 4.2. By signing the entry the participants agree to the official regulations of the NEZ CHAMPIONSHIP as well as to the organizing regulations of the Organizing regulations of Trophy raid NEZ event and regulations of the current race.
- 4.3. It is allowed to change the second driver until the administrative check. This change must be approved by the organiser. If the team wants to exchange two of its members or the first driver than this change needs to be documented with written confirmation by the organiser, which becomes an inseparable part of team's entry and the team receives a copy of it.
- 4.4. The entry fee of the race is 200 EUR
- 4.5. Organizer has the right to determine the amount and the time limit of the entry fees.
- 4.6. Entry fees are fully refunded to those participants, whose entries were not accepted. In case if the race is cancelled or postponed for more than 24 hours.
- 4.7. Organizer refunds the entry fee partially (up to 50%) if the participant could not participate in the race due to approved force majeure conditions.

- 4.8. Entry fees are refunded during one month after the end of the race.
- 4.9. Organizer has the right to include extra fees in to the race regulations for car service, transport, hotels and public catering.
- 4.10 Entry fees do not cover the insurance policies; the participants are responsible that they have all the insurance policies needed from the beginning of the race till the race ends.

#### Chapter 5. Identification and advertisements.

- 5.1. Organizer provides each crew with two race emblems and two racing numbers.
- 5.2 Race emblems (max size 43 cm width and 21.5 cm height) must contain status of the race the official name of the race and depending on the organizers choice either the name or the logo of main promoter.
- 5.2.1 Front race emblem must be placed vertically on the front face of the car in the rectangle formed by these following lines:
- Line going through the axis of the wheels
  - Two vertical lines, going trough the inner sides of the front lamps
  - A horizontal line going through the lowest point of the front lamps
- It is also possible to place the emblem on the front side of the hood.  
The front emblem must be the first inscription to meet the eye except the cars manufacturer logo.
- 5.2.2 Rear emblem also must be placed vertically on cars body or the rear window if it is not transparent.
- 5.2.3 Emblems must not cover the cars registration number plates.
- 5.3. Racing numbers (size 50 cm width and 52 cm height, if it is impossible than 45x45) must be placed on the front doors of the vehicle.
- 5.4. If during the race an incorrect placement or absence of one of the race emblems or racing numbers is detected, a fine to the tune of 10% of the entry fee is charged. If during the race an incorrect placement or absence of both of the race emblems or racing numbers is detected, a fine to the tune of 20% of the entry fee is charged.
- 5.5. Surnames and names, (pseudonyms) of 1<sup>st</sup> and 2<sup>nd</sup> drivers (drivers for ATV) and their national flags with minimal height of 30mm must be placed on either both front sides or doors of vehicle. If either one of these identification signs is missing fine to the tune of 10% of the entry fee is charged.
- 5.6. Participants have the right to position all kinds of advertisements on their cars as long as it:
- does not contradict the law
  - does not contradict organizers indications

- is not offensive
- is not placed on racing numbers and emblems
- is not on windscreen
- does not affect visibility

- 5.7. Spots reserved by the organizer for obligatory advertisements are:
- 9cm x 43cm bottom zone of the emblem
  - 14cm x 50cm zone on the top and bottom of the racing number
  - Two 10 cm high and 25 cm wide stripes on both sides of the top of the windscreen.
- 5.8. Place for organizers non obligatory advertisements, both back doors and sides of the vehicle.
- 5.9 Teams are responsible for placement of all the advertisements on their vehicles if a team is caught without the advertisements or has positioned those incorrect - 10% of the entry fee is charged, if the team is caught the second time for the same reason - 100% of the entry fee is charged.
- 5.10. If team refuses to place advertisements at all 100% of the entry fee is charged.
- 5.11. Advertisement placement scheme is handed out at the registrations.

#### Chapter 6. Point scores.

- 6.1 The winning crews of TR1, TR2, TR3 and OPEN categories are announced in 2011.
- 6.1.1. The crew or team who gains the most points during all the 3 series of the 2011 NEZ CHAMPIONSHIP is declared winner in its category.
- 6.2. According to the official calendar of 2011 NEZ CHAMPIONSHIP there are 3 series.
- 6.3. In each of the series points are allocated in each category separately. If some drivers have equal amount of points then they are judged by the last race. If these drivers again the same amount of points the priority is given based on their first point match, if they again have the same amount of the points the places are shared.
- 6.4. Every participant receives points in the category that his vehicle was classified.
- 6.5. Crew has to participate at least in two of the three series of the NEZ CHAMPIONSHIP to be listed in standings of CHAMPIONSHIP.
- 6.6 The points are calculated according to the table given in 1<sup>st</sup> annex of these regulations.

#### Chapter 7. Awards.

7.1. Crews who collect the most points are winners. They receive cups, medals, diplomas and prizes.

7.2. Cups, medals, diplomas are given to the first second and third crew.

7.3. Awards are funded by the organizer.

Chapter 8 . Organizers of 4x4 NEZ CHAMPIONSHIP 2011:

1. Latvia 1-3 April - Kurland trophy 2011

Mr. Arnis Namajuns  
e-mail: [namajuns@ml.lv](mailto:namajuns@ml.lv)  
<http://www.4x4lv.lv>

2. Lithuania 30 september-2 October – 4x4 Gladiatorai 2011

Mr. Audrius Sutkus  
e-mail: [audrius@bastunas.lt](mailto:audrius@bastunas.lt)  
[www.4x4gladiatoriai.lt](http://www.4x4gladiatoriai.lt)

3. Estonia 18 – 20 November A.Sults Memorial 2011

Oliver Sults  
[oliver@luige-team.ee](mailto:oliver@luige-team.ee)  
<http://www.4x4offroad.ee>

## Classification „NEZ CHAMPIONSHIP”

### Technical regulations for cars prepared for off-road (Group TR1) 2009-2012 year

In case of cars inadequacy for group TR1 by one or more parameters, which do not influences cars passability, security of crew and persons around, concerned person should submit application in written form to technical commission in order to be authorized to start in group TR1. All organizers of the competition must verify submitted authorization.

## Category sport

### 1. Definition

Off-road car with wheel formula 4x4, specially prepared to participate in competitions:

- Homologed FIA cars in groups T1, T2;
  - Stockcar (Series production cars) produced at least 1000 identical units.
- It is allowed to compare car parts with serial parts during technical inspection.

### 2. Enhancement.

Enhancement of any car part should follow: used material repeats shape of part, if enhancement in not talked out in concrete paragraph of these rules.

Cars exterior must be kept, as it is original.

### 3. Seats.

It is allowed to install any car seats. Seats must be safely fixed. Third row of seats can be removed. Cars must have room to accommodate at least two persons.

### 4. Cars construction

If in one or other paragraph of these technical regulations there are list of allowed rebuilds, changes or upgrades, then all other changes, not mentioned in the list, are question less **forbidden**.

The only work which may be carried out on the car is that necessary for its normal servicing or for the replacement of parts worn through use or accident. The limits of the modifications and fittings allowed are specified hereinafter. Apart from these, any part worn through use or accident can only be replaced by an original part identical to the damaged one.

It is strongly stated that cars must be stockcars, recognizable (identifiable) by factory data (catalogue or homologation form).

All cars must be registered in traffic police institutions and allowed to participate in road traffic ( must have ticket or mark that car has passed roadworthiness test)

Any car changes, adds or modifications must not conflict with countries, where competition is taking place, laws.

### 5. Car weight

Car weight must not be less than 800 kg and not more than 3500 kg.

## **6. Technical requirements**

### **Wheel formula**

It is allowed to use units that realize special wheel formula 4x4, it is:

- Total wheel number touching ground must be four;
- Total number of driving wheels must be four.

Usage of any other wheel formula is strongly forbidden.

Engine.

Original.

Cooling circuit: Original.

Air filter: it is forbidden to take air from cockpit.

Petrol: It is allowed to use only officially provided petrol marks, sold by authorized providers. Any additive to petrol is strongly forbidden. In engine as oxidant must be used only air from surrounding atmosphere.

Exhaust: original.

Transmission.

Original.

Suspension

It is prohibited to change walk of suspension system and lift of the system.

Axles

Original. It is allowed to install blocking system.

6.6 Wheels and tires.

It is allowed to use wheels not more than 820 mm, measured at 2,0 atm., it is prohibited to use wheels from special cars, agricultural machines, and special road technique units. Tyre width is restricted to 320mm, and tyres must be covered by mudguards or arch extensions. It is forbidden to cut in protector. Discs must be factory produced. Discs planed for side tire fixing are forbidden.

6.7.Brake system

Original, including lay brake.

6.8.Steering system

Original. It is allowed to interchange steering wheel with another factory provided.

6.9.Bodywork

Original. Bodywork lift is forbidden.

6.9.1. Exterior:

It is allowed to install plastic parts for wheel arches.

Body protection:

Allowed to use additional protecting elements under body to realize protection of the following car parts: engine, cooler, suspension, gearbox, transfer box, tank, transmission, exhaust.

Bumper and other additional protecting elements:  
“in year 2004 redaction” Original. It is allowed to make a cut out if adding a winch, but not bigger than winch dimensions.

#### 6.9.2. Towing-eye

Car must have at least one towing-eye in front and one in back side of car, and towing-eyes must be demonstratively marked.

#### 6.10. Electrical system

Original. Layout of all elements – original. ACC layout – no changes.

Lighting system:

Lighting elements are not limited, but must correspond country laws, the competition is taking place. Present lighting elements must be in working order in moment of technical commission.

Main electrical equipment switch:

Mass electricity switch can be installed.

#### 6.11. Fueling circuit.

Original. Allowed enhancement.

#### ~~6.12. Winch and other special equipment.~~

~~Allowed to install not more than one winch, provided in series by registered trade mark. If winch is present, then car must be equipped with: winch rope dampener, sling (minimal wide 50 mm). During car movement all additional units (winch rope, rope extends, slings, fixing hooks, rope loop, blocks, dampener) must be safely fixed.~~

#### 6.12. Winch and other special equipment. (Recomended from year 2011, must from year 2012)

Allowed to install not more than one winch, provided in series by registered trade mark.

As winch it is understood device consisting of (notmore than one):

- Power drive (including electrical engine)
- spaad-reducer
- reel
- case or frame
- brake system
- rope

- If winch is present, then car must be equipped with: winch rope dampener, sling (minimal wide 50 mm). During car movement all additional units (winch rope, rope extends, slings, fixing hooks, rope loop, blocks, dampener) must be safely fixed.

6.13. Safety cage

Interior safety cage can be installed. Construction of main safety rollbar can be seen in attachment No. 2, or is factory produced. All parameters and ways of making main safety rollbar must correspond FIA rules or must be homologued.

6.14. Safety belts

Car must have at least three point car safety belts, factory produced, for all crew members.

6.15. Extinguisher.

In car must be extinguisher, factory made, it must contain not less than 2 kg extinguish structure (Freon-12, bromethylen, carbonic acid, extinguishing powder), concentrated in one or two bottles.

Usage of foam extinguisher is forbidden.

Extinguisher must be easily reachable for pilot and co-pilot. It must be safely fixed, and must ensure quick and easy removal without using any tool. On bottle must be shown: net weight, extinguisher weight, and bottle weight.

7. Additional equipment

Additional equipment must be as given in attachment No.1.

**Obligatory additional devices**

**1. First aid kit.**

Car has to be fitted with special first aid kit. All kit components must be with legal period of use and with no visible damage of wrapping. First aid kit must be in easy reachable place, and have waterproof package. In first aid kit must be:

**2. Communications**

To ensure safety, and temporary medical assistance, it is recommended to equip car with radio station MW-diapason (27 MHz ). As intermedia can be used radio station using other diapason, radio, cellular and satellite phones.

**Technical regulations for  
vehicles prepared for Trophy-raid championships group „OPEN”  
years 2009-2012.**

In case of cars inadequacy for technical regulations of group OPEN by one or more parameters which do not influence cars passability, security of crew and persons around, concerned person should submit an application in written form to Trophy raid commission in order to be authorized to compete in group OPEN.

**1. Definition**

Specially prepared, all wheel drive series production cars registered at Road Traffic Safety Department. All the vehicles of OPEN group must possess third party insurance and a certificate that the vehicle has passed the roadworthiness test.

**2. Enhancement.**

Enhancement of any car part is allowed if the material used copies the shape of the enhanced part as well as if enhancement is not specified in certain paragraph of these regulations.

**3. Seats**

It is allowed to install any car seats. Seats must be safely fixed. Third row of seats can be removed. Cars must have at least two seats. All the seats must have 3 point safety belts. If vehicles back seat is installed differently than it is planned by its manufacturer than at least 4 point seat belts are required.

**4. Cars construction**

If some modifications are expressly authorized in a specific paragraph of these regulations all other modifications are forbidden. If some modifications are expressly forbidden in a specific paragraph of these regulations all other modifications are allowed.

**5. Car weight**

Car weight must not be less than 800 kg and not more than 3000 kg. Only technical commissar may do the vehicle weight check test. During vehicle weight test vehicle weight is checked with all its tanks (fuel, oil, cooling, brake fluid) being full. During this test windshield and headlamp washer fluid reservoirs must be empty.

**6. Wheel formula**

It is allowed to use units with wheel formula 4x4, it is:

- Total wheel number must be four;
- Total number of driving wheels must be four.

Usage of any other wheel formula is strongly forbidden.

## **7. Engine**

Only internal combustion engines are allowed.

Cooling radiators location may be changed. If so it has to be placed outside cars cockpit and separated from cockpit by waterproof partition walls.

Exhaust systems noise level must not exceed 103dB limit.

Exhaust systems modifications must not cause any changes in vehicles frame or self-supporting construction. Air intake from cockpit is strictly forbidden.

## **8. Transmission**

Cars original transmission may be replaced by any series production cars transmission or its parts. (Donor cars gross vehicle weight (GVW) must not exceed 3000kg)

Cars original gearbox and transfer case may be replaced.

## **9. Suspension**

Any type of suspension is allowed. It is prohibited to place any moving parts of the suspension inside cockpit.

Use and number of coil, leaf, torsion springs and shock absorbers is not restricted.

It is allowed to lift suspension system and vehicles body. Lift insert fixation points must be welded or bolted to vehicles frame.

## **10. Axles**

Cars original axles may be replaced by any series production cars axles. (Donor cars GVW must not exceed 3000kg)

Cars original gearbox and transfer case may be replaced.

Vehicles clearance (measured from lower point of speed reducer to horizontal plane on which the vehicle is placed during measurement) must be 200 – 330 mm. During clearance check vehicle must be equipped with tires specified in 11<sup>th</sup> paragraph of these regulations (tyre pressure must be 1,5 atm). If during the race tyres are changed clearance must be checked repeatedly. Clearance is measured for both axles and the major dimension is taken into account. For cars with independent front suspension only rear axle clearance is taken into account. It is allowed to install blocking differentials. Type and number of the differentials is not restricted.

## **11. Wheels and tyres**

It is allowed to use only series production wheels produced for cars with GVW not exceeding 3500kg. Only pneumatic tyres produced for cars with GVW not exceeding 3500kg are allowed. Maximum tyre diameter, measured at 1,5 atm pressure, must not exceed 840 mm. Tyre diameter must be in compliance with clearance restrictions specified in 10<sup>th</sup> paragraph of these regulations. It is forbidden to cut in tyre protector. Use of anti slip chains forbidden, tyre side fixings with bedlocks allowed. Mud terrain tyres and tyres with increased passability protector (protector must be at least 5mm) are allowed. Tyre width is not restricted, but tyres must be covered by mudguards or arch extensions. Tyre diameter is measured at 1,5 atm pressure, tyres static deformation is not taken into account. All the tyres are measured including spare tyres.

Screw-bolt wheel fixation may be changed to screw-nut wheel fixation with condition that the number of fastenings and the diameters of thread are not changed.

Spare wheels if located inside cockpit must be tightly fixed.

## 12. Brake system

Brake system must be in compliance with technical regulations of Road Traffic Safety Department. Two circuit brake system is allowed. The layout of brake lines may be changed. Additional protection of brake lines is allowed. All driven wheels must be equipped with brakes. Brake system must be in a sound condition.

## 13. Bodywork

It is allowed to shorten the vehicles body overhang up to suspensions fixation points. Vehicle body parts located behind cockpit may be removed. Body parts may be replaced by visually resembling parts made out of lighter materials. Replaced parts must guarantee the same level of safety that was ensured by original parts. Vehicle frame or self supporting body must be from a series produced car with GVW not exceeding 3000kg. It is allowed to shorten the vehicles frame overhang up to suspensions fixation points. Reinforcement of frame is allowed.

Cars with soft tops must have additional metal roof installed over the seats with following dimensions:

**Width:** as wide as the upper side of the windscreen

**Length:** must cover the space between the windscreen and either the back of the car's backseat (passenger seat – in case if there are only two seats in the car) or the main arc of the safety cage.

**Minimum Thickness:** 1mm for sheet metal; 2mm for aluminum

Factory manufactured plastic hard tops are allowed.

It is allowed to use additional protecting elements under body. Bumper and other additional protecting elements are not restricted.

**Exterior:** Car must have wings and mudguards on all wheels.

Wheel arch extenders must cover the wheels. Plastic wheel arch extenders are allowed. Car's registration plates must be placed on the front and rear sides of the car. Equipment located on vehicles outside must be tightly fixed and must not jut outside vehicles dimensions. Equipment must not cause any difficulties to the team while getting in and out of vehicle. Windscreen is mandatory. Doors must not be modified. If the vehicle does not have doors or doors do not have hard construction, doors must be installed. Installed doors must have metal construction at least 30 cm above the horizontal part of drivers seat. Door locking mechanisms must prevent the possibility of unwarranted door opening. Additional hood fixation mechanisms must be installed to prevent unnecessary opening of the hood. Location of moving parts of transmission, suspension or steering system is not allowed inside cockpit.

### Towing-eye

Car must have at least one towing-eye in front and one in back of car and towing-eyes must be marked with bright yellow or orange color paint that differs from vehicles paintwork. Towing-eyes must be attached to frame or self supporting body. Their minimum diameter is 30 mm. It is allowed to use factory manufactured towing-eyes.

## 14. Electrical system

All the contacts must be insulated. Vehicles battery type, volume, placement and connecting cables are not restricted. It is allowed to install not more than two batteries. If battery is placed inside cockpit it must be placed inside insulated box providing needed ventilation for the battery conducting the vapor outside the cockpit.

**Lighting system:**

Lighting elements are not limited. Original lighting elements may be replaced with one condition that the installed elements ensure the same functions as the original ones. During technical commission all the lights must function.

**Main electrical equipment switch:**

Main electricity switch must be installed that functions for all electric circuits. It must function without producing sparks and must be positioned so that both pilot and co-pilot can reach it from their seats with fastened safety belts. Turning off the main electrical switch must turn off the engine.

**15. Fueling system.**

It is allowed to use standard fuel tanks and it is also allowed to change them. Fuel tank must be separated from cockpit by a fireproof partition wall. Fuel tanks ventilation must not be connected with cockpit. Fuel tank and its caps must not be located outside vehicles body dimensions. Fuel tank caps must have mechanisms that prevent their opening by chance. Fuel lines may be modified with condition that inside vehicles cockpit they consist of a single piece metal tube. Any fuel line connections are forbidden inside cockpit with the exception of connections between two metal tubes or between a metal tube and a homologated fuel line.

**16. Jacks.**

It is forbidden to use stationary installed jacks of any kind (mechanical, pneumatic, hydraulic etc.) Number of non stationary jacks is not restricted.

**17. Winch and other special equipment.**

It is allowed to install not more than one electrical, mechanical or hydraulic winch, provided in series by registered trade mark. Its power must be 1,4 times greater than vehicles GVW. It is allowed to use “spools” – self pulling up devices installed on wheels. Winch cable, its extension, strops, hooks, carabines and blocks must withstand twice as big tension force as the winch is able to produce. To prevent tree damaging, during winch use it is mandatory to use at least 50 mm wide strop around the trees to protect bark. While using winch a winch cable damper must be used.

**18. Safety cage**

It is recommended to use safety cage. Both interior and exterior safety cage can be installed. Construction of main safety rollbar can be seen in attachment No. 1, or it must be factory produced. All parameters and ways of making main safety rollbar must be in compliance with attachment No. 1 or must be homologated. Cars with original metal roofs must have a main safety rollbar with at least four fixation points to the frame. Cars without original metal roofs must have a main safety rollbar with at least six fixation points to the frame. Safety carcass can be a part of vehicle body. It is recommended to use FIA certified carcasses.

**19. Obligatory equipment**

Each car must have a fire extinguisher, factory made, it must contain not less than 4(2+2) kg fire extinguish structure (Freon-12, bromethylen, carbonic acid, extinguishing powder), concentrated in one or two bottles. Every fire extinguisher bottle must have pressure indicator, expiry date and must be in sound condition. Usage of foam extinguishers is forbidden.

Fire extinguisher must be easily reachable for pilot and co-pilot. It must be safely fixed, and must ensure quick and easy removal without using any tool. On bottle must be shown: net weight, extinguisher weight, and bottle weight.

Car has to be fitted with special first aid kit. All kit components must be with legal period of use and with no visible damage of wrapping. First aid kit must be in easy reachable place, and have waterproof package.

Car must have one reflective emergency stop triangle sign.

One winch cable damper must be used while using winch. The damper must not be fixed on winch cable, but has to slide along it. It must be colored in bright color, easy distinguishable from distance, 45 cm high(folded), 50cm wide and weight at least 0,5 kg. It is allowed to use plastic, textile, and all other materials except paper, cardboard and other wood pulp products. While using the winch damper must be placed approximately in the middle of winch cord.

## **20. Communications**

To ensure safety, and temporary medical assistance, it is recommended to equip car with radio station MW-diapason (27 MHz). As means of communication can be used radio station using other diapason, radio, cellular and satellite phones.

## Classification „NEZ 4X4 CHAMPIONSHIP”

### Technical regulations for cars prepared for off-road (Group TR2) 2009-2012 year

In case of cars inadequacy for group TR2 by one or more parameters, which do not influences cars passability, security of crew and persons around, concerned person should submit application in written form to technical commission in order to be authorized to start in group TR2. All organizers of the competition must verify submitted authorization.

## Category sport

### 1. Definition

Off-road car with wheel formula 4x4, specially prepared to participate in competitions:

- Homologed FIA cars in groups T1, T2;
  - Stockcar (Series production cars) produced at least 1000 identical units.
- It is allowed to compare car parts with serial parts during technical inspection.

### 2. Enhancement.

Enhancement of any car part should follow: used material repeats shape of part, if enhancement in not talked out in concrete paragraph of these rules.

Cars exterior must be kept, as it is original.

### 3. Seats.

It is allowed to install any car seats. Seats must be safely fixed. Third row of seats can be removed. Cars must have room to accommodate at least two persons.

### 4. Cars construction

If in one or other paragraph of these technical regulations there are list of allowed rebuilds, changes or upgrades, then all other changes, not mentioned in the list, are question less **forbidden**.

The only work which may be carried out on the car is that necessary for its normal servicing or for the replacement of parts worn through use or accident. The limits of the modifications and fittings allowed are specified hereinafter. Apart from these, any part worn through use or accident can only be replaced by an original part identical to the damaged one.

It is strongly stated that cars must be stockcars, recognizable (identifiable) by factory data (catalogue or homologation form).

All cars must be registered in traffic police institutions and allowed to participate in road traffic ( must have ticket or mark that car has passed roadworthiness test)

Any car changes, adds or modifications must not conflict with countries laws, where competition is taking place.

### 5. Car weight

Car weight must not be less than 1000 kg and not more than 3500 kg.

Decision about car weight check is on technical commission delegate.

Car weight must be checked “as car is” and the result compared with limits.

All tanks consisting fluids (oil, cooling, brake, heating and others) must be filled to normal level mentioned by producer. Exceptions: windscreen and light cleaner fluid tanks, brake cooling tanks, fuel tank, and water spray system tanks, those tanks must be empty during weight control.

## **6. Technical requirements**

### **6.1. Wheel formula**

It is allowed to use units that realise special wheel formula 4x4, it is:

- Total wheel number touching ground must be four;
- Total number of driving wheels must be four.

Usage of any other wheel formula is strongly forbidden.

### **6.2. Engine.**

Allowed to use any petrol and diesel engine, inter alia equipped with air blow up systems.

Interchange of engine must not conflict with country laws, where competition is taking place.

**Cooling circuit:** it is forbidden to remove radiator from engine room.

It is forbidden to equip car cooling circuit with extra radiator in cockpit.

Original heating elements must stay in original dimensions.

**Air filter:** it is forbidden to take air from cockpit

**Petrol:** It is allowed to use only officially provided petrol marks, sold by authorized providers. Any additive to petrol is strongly forbidden. In engine as oxidant must be used only air from surrounding atmosphere.

**Exhaust:** Allowed to use any exhaust system, providing sound level not higher than talked out in country laws, where competition is taking place.

Changes in exhaust system must not influence bodywork changes.

Maximum sound level is 103 Db. (For international competition)

**6.3. Transmission.** Transmission type must correspond car and engine model.

#### **Gear box:**

Allowed to change gear box. Gear box inside system is not limited.

#### **Transfer box:**

Allowed to change transfer box. Transfer box inside system is not limited.

### **6.4. Suspension**

Forbidden to change principles of car suspension. Allowed to change vertical suspension fixing points on body or axles in order to use wheels with grater diameter.

If such changes made, it should be safely fixed (weld, on bolt or other). Allowed to put XXXX under or upon axles.

#### **6.4.1. Springs**

Forbidden to change spring type.

**Dampers:**

Allowed to add dampers but it has to be not more than two dampers per one wheel.  
Allowed to change dampers with no limits.

**6.4.2. Axles.**

Allowed to use any kind of axles, if axles are produced in series for given car brand. Maximal clearance, measured from lower point of axle central speed-reducer, to flat horizontal ground where the car is standing on, must be no less than 200 mm, and not more than 340 mm. During clearance measuring on car must be adjusted competition tyres(see paragraph 6.5.) air pressure in tyres not less than 2,0 atm. If tyres changed this parameter must be remeasured.

Clearance is measured on booth rear and front axle.

Highest measure is taken in account.

Allowed to use differential gear with blocking system. There are no limits on number or type of differential gear with blocking system.

**6.5. Wheels and tyres.**

On wheel, dimensions there are no limits

Allowed to use only car pneumatic tyres, diameter less than 775 mm and more than 915 mm, measured when pressure 2,0 atm. For every cars tyre maximum outside diameter should be synchronized with cars clearance (see 6.4.2.). Forbidden to use tyres from farm machines and special cars or route technique units.

Allowed to use mud terrain tyres and tyres with elevated passability with minimal remaining protector height 5 mm.

Tyres protector width is not limited, except, that tyre all width long must be covered with arches or arch extenders.

Diameter is measured when tyre pressure is 2,0 atm., in straight diametric line traversing centre point of tyre, and is not vertical anent ground ( during measurement tyre squeeze should not be taken in account). Measuring must be performed on every tyre (including spare wheels and other), going to use in competition.

Tyre bolt fastening could be changed with threaded studs, screw-nuts if number of fastening points and component thread diameter stays as was.

Forbidden to install any contra slip out equipment (e.g. chains, special framing, and other)

**6.6. Brake system**

Allowed to use brake system according to Country roadworthiness test demands.

Allowed to change brake artery placement and protection.

**6.7. Bodywork**

Allowed to protect and install every hanger.

**6.7.1. Roof:**

Cars having soft roof coverage, must have metallic roof (protection) over crew, and in mean time width of firm part must be not less than upper part of every screen width and length not less than from upper part of every screen to back edge

of crew seat or to main safety circle. Minimal metal thickness: 1mm – steel, 2mm – aluminium.

Allowed to use plastic roof, factory made.

#### 6.7.2. Exterior

Forbidden to curtail car body. Allowed to cut off car body's upper part to "windowsills" behind edge of crew seats. Allowed to cut out wheel arches. Must install tyre arch extenders.

#### Body protection:

Allowed to use additional protecting elements under body to realize protection of the following car parts: engine, cooler, suspension, gearbox, transfer box, tank, transmission, exhaust.

#### Bumper and additional protecting equipment:

No limits, if new bumper usage is not conflicting with countries, where competition is taking place, laws.

#### Windows:

Forbidden to change front screen material.

#### Wings and tyre arch's:

Allowed small changes in tyre arch if they needed to install big diameter tyres.

Allowed to install tyre arch extenders, installation must be safe. Wheels (tyres and discs) must be covered by arch or extender in all width, if watching from upper side.

#### Doors:

Forbidden to change original front side door. In case if there are no original front door or it is not firm, firm door must be installed and it should open/close and has to be equipped with lock device which excludes door self opening. In that case it is allowed to add firmly fixed parts in door aperture in stead of doors, then distance from seat level to upper part of fixed part must be not less than 30 cm.

#### Doorsteps:

Allowed to cut off body doorsteps. Allowed to strengthen doorsteps with no limits.

#### Removable body parts. Soft roof:

For serial cars with easy removable body parts (plastic roof, soft roof), allowed to change these element shape and even remove them, if filling rules 6.7.1.

#### Additional front engine cover lock:

Front engine cover must have additional lock mechanism, preventing from self opening during car movement.

#### 6.7.3. passenger convenience:

All lever place can be upgraded, to make them more convenient and more easy to use, for example, taller parking brake lever and other.

#### 6.7.4. Seats

Allowed to install every car seat. They must be safely fixed.

#### 6.7.5. Body lift.

Allowed to change distance between body and frame, but not more than 76 mm.

#### 6.7.6. Spare wheel

Spare wheels can be moved into cockpit, if they are safely fixed.

#### 6.7.7. Towing eyes

Car must be equipped with towing eyes: Car must have at least one towing-eye in front and one in back side of car, and towing-eyes must be demonstratively marked. This towing-eye must be very firmly fixed to cars body if there is no frame, otherwise to frame. It will be clearly visible and painted in yellow, red or orange. It must have closed shape and has to be firm, minimum inside diameter: 30 mm. Allowed to leave original "hook" towing eye.

#### 6.8. Electrical system

If changing electrical system, all wires must be insulated.

##### Battery:

Type, capacity and cables for battery connections are not limited. Allowed to install not more than two batteries. Batteries must be safely fixed. In case the battery is located in cockpit it must be in hermetic partition and as obligatory is ventilation system ensuring ventilation system which can conduct steam out of battery partition, and it must lead to outside of car.

##### Generator:

No limits.

##### Lighting system:

Lighting elements are not limited, but must correspond country laws, the competition is taking place. Present lighting elements must be in working order in moment of technical commission.

##### Main electrical equipment switch:

Car must be equipped with main electrical equipments switch (battery, generator, lighting elements, alarm system, ignition, starter and other). It must work without sparking and must be in reachable area for pilot and copilot. Turning off all electrical equipment must be followed by engine stop apart from its type (diesel or petrol).

#### 6.9. Fuel circuit

##### Fuel tank

Allowed to interchange, change or replace original fuel tank. Fuel tanks must be separated from cockpit with flame-proof material.

Forbidden to lead out fuel tank ventilation into cockpit.

Filling neck and cap must not be put out of car body. As fuel tank cap can be used every lock system which can provide accidental cap opening in case of hit or incomplete lock.

##### Fuel pipes:

Allowed to interchange, replace, move and reinforce fuel pipes, taking in account that in cockpit it must be in entire metallic piece. Any fuel pipe joints in cockpit are forbidden except pairs metal-metal, metal – homologued fuel pipe.

#### 6.10. Jacks

Hi-jacks, an jacking points are not limited.

Forbidden use of stationary adjusted, jacking systems of any type (mechanical, pneumatic, hydraulic and other).

#### 6.11. Winch and additional equipment

Car must be equipped with at least one winch (one not manual winch), traction parameters must exceed car weight at least 1,4 times. Allowed to use winch of any type (electrical, mechanical, hydraulic), with condition, that winch is produced serially and by one of registered trade marks.

Adjusting more than two winch's is forbidden.

Allowed wheel spools.

To ensure car safety it must be equipped with rope dampener.

To avoid tree damaging during winch usage, car must be equipped with flat, corrosion-resistant sling (minimal wide 50 mm).

Winch rope, rope extenders, sling, fixing hooks, rope loop, blocks, dampener must be safely fixed.

#### 6.12. Safety cage.

It is allowed to adjust interior and exterior safety cage. Cars must be equipped with main safety rollbar. Construction of main safety rollbar can be seen in attachment No.

2, or is factory produced. All parameters and ways of making main safety rollbar must correspond attachment No. 2 or be homologued.

Cars having original metallic roof must have steel safety frame over crew heads with at least four fixing points to car frame.

Cars not having metallic roof must have steel safety cage, consisting main rollbar and front rollbar and at least 6 fixing points to frame.

Recommended to use FIA certificated cages.

#### 6.13.Safety belts.

Car must have at least three point car safety belts, factory produced, for all crew members. Third or side seat must be equipped with at least four point seat belt factory produced.

#### 6.14.Extinguisher

In car must be extinguisher, factory made, it must contain not less than 4 kg (2+2) extinguish structure (Freon-12, bromethylen, carbonic acid, extinguishing powder), concentrated in one or two bottles.

Usage of foam extinguisher is forbidden.

Extinguisher must be easily reachable for pilot and co-pilot. It must be safely fixed, and must ensure quick and easy removal without using any tool. On bottle must be shown: net weight, extinguisher weight, and bottle weight.

### 7. Additional equipment

Additional equipment must be as given in attachment No.1.

#### **Obligatory additional devices**

##### **1. First aid kit.**

Car has to be fitted with special first aid kit. All kit components must be with legal period of use and with no visible damage of wrapping. First aid kit must be in easy reachable place, and have waterproof package. In first aid kit must be:

##### **2. Communications**

To ensure safety, and temporary medical assistance, it is **recommended** to equip car with radio station MW-diapason (27 MHz ). As intermedia can be used radio station using other diapason, radio, cellular and satellite phones.

## Classification „4X4 EURO CHAMPIONSHIP”

### Technical regulations for cars prepared for off-road (Group TR3) 2009-2012 year

In case of cars inadequacy for group TR3 by one or more parameters, which do not influences cars passability, security of crew and persons around, concerned person should submit application in written form to technical commission in order to be authorized to start in group TR3. All organizers of the competition must verify submitted authorization.

## Category sport

### 1. Definition

Off-road car with wheel formula 4x4, free construction and original car's, corresponding technical demands for given group. Minimal produced car number is not limited.

### 2. Reinforcement

Every car part reinforcement is allowed with condition that reinforcement repeats part shape.

### 3. Number of seats

Car must have cockpit for at least two persons.

### 4. Car construction

If in one or other paragraph of these technical regulations there are list of allowed rebuilds, changes or upgrades, then all other changes, not mentioned in the list, are question less **forbidden**. If it is given list of forbids or limits, than any other technical changes not mentioned are question less **allowed**.

Cars must correspond safety demands.

All cars must be registered in traffic police institutions and allowed to participate in road traffic ( must have ticket or mark that car has passed roadworthiness test)

### 5. Car weight

Car weight is limited and is 3500 kg.

Decision about car weight check is on technical commission delegate.

Car weight must be checked “as car is” and the result compared with limits.

All tanks consisting fluids (oil, cooling, brake, heating and others) must be filled to normal level mentioned by producer. Exceptions: windscreen and light cleaner fluid tanks, brake cooling tanks, fuel tank, and water spray system tanks, those tanks must be empty during weight control.

### 6. Technical demands.

#### 6.1. Wheel formula.

It is allowed to use units that realise special wheel formula 4x4, it is:

- Total wheel number touching ground must be four;
- Total number of driving wheels must be four.

Usage of any other wheel formula is strongly forbidden.

## 6.2. Engine

Allowed to adjust any engine.

Radiator must be separated from cockpit with fluid impenetrable screens and briers or moved out of it's bounds.

Allowed to use any exhaust system, providing sound level not higher than talked out in country laws, where competition is taking place.

Changes in exhaust system must not influence bodywork changes.

Maximum sound level is 103 Db. (For international competition). Forbidden to take air from cockpit.

## 6.3. Transmission

No limits in transmission.

Forbidden to adjust any rotating transmission parts in cockpit.

## 6.4. Suspension

Allowed to use any suspension types. Forbidden to adjust moving suspension parts into cockpit.

### 6.4.1. Springs

Spiral spring, damper, torsion, usage and number are not limited.

### 6.4.2. Axles.

Allowed to adjust axles build on serial part basis.

Maximal clearance, measured from lower point of axle central speed-reducer, to flat horizontal ground where the car is standing on, must be no less than 200 mm, and not more than 500 mm. During clearance measuring on car must be adjusted competition tyres(see paragraph 6.4.) air pressure in tyres not less than 2,0 atm. If tyres changed this parameter must be remeasured.

Clearance is measured on both rear and front axle.

Highest measure is taken in account.

For cars with independent suspension in front, clearance is measured on rear axle.

Allowed to use any differential gear with blocking system. Allowed to change any axle detail construction and parameters.

### 6.4.3. Suspension lift

Pads used for vertical change of suspension fixing points to frame must be firmly fixed (weld or bolts)

### 6.4.4. Wheel basis

No limits.

## 6.5. Wheels and tyres.

Allowed to use pneumatic tyres, inter alia tyres from farm machines and special cars or route technique units, which diameter are not less than 815 mm and not bigger than 1043 mm – including, measured when pressure in tyre is 2,0 atm. Tyre diameter must be harmonized with car clearance (see 6.4.2.)

Protector width is not limited.

Diameter is measured when tyre pressure is 2,0 atm., in straight diametric line traversing centre point of tyre, and is not vertical anent ground ( during measurement tyre squeeze should not be taken in account). Measuring must be performed on every tyre (including spare wheels and other), going to use in competition.

Tyre bolt fastening could be changed with threaded studs, screw-nuts if number of fastening points and component thread diameter stays as was.

Forbidden to install any contra slip out equipment (e.g. chains, special framing, and other)

6.6. Braking system. All wheels must have brakes.

Allowed to use brake system according to Country roadworthiness test demands.

Allowed to change brake artery placement and protection.

6.7. Bodywork and framework

Allowed to change original stockcar bodywork, as well as remove or change any part shape.

Allowed to interchange suspended body parts to analogical, made from lighter material, with condition that safety parameters are as they were. Allowed to adjust any reinforcing parts in framework. Allowed to reinforce framework. Forbidden to adjust joints in bodywork.

6.7.1. Exterior. No limits

Roof:

Cars having soft roof coverage, must have metallic roof (protection) over crew, and in mean time width of firm part must be not less than upper part of every screen width and length not less than from upper part of every screen to back edge of crew seat or to main safety circle. Minimal metal thickness: 1mm – steel, 2mm – aluminium.

Allowed to use plastic roof, factory made.

Body protection:

Allowed to use additional protecting elements under body for protection.

Bumper and additional protecting equipment:

Bumper usage must not conflict countries, where competition is taking place, laws.

Windows:

Obligatory front screen presence.

Wings and tyre arch's. Arch extenders are obligatory.

Car must be equipped with wings and splashers behind all wheels. Allowed to install tyre arch extenders, installation must be safe. Wheels (tyres and discs) must be covered by arch or extender in all width, if watching from upper side.

Doors:

Front door must be firm and it should open/close and has to be equipped with lock device which excludes door self opening. It is allowed to add firmly fixed parts in door aperture in stead of doors, then distance from seat level to upper part of fixed part must be not less than 30 cm

Additional front engine cover lock:

Front engine cover must have additional lock mechanism, preventing from self opening during car movement.

6.7.2. Passengers convenience:

Forbidden to adjust rotating engine, transmission, suspension, steering trapezium parts into cockpit.

6.7.3. Seats

Allowed to adjust any car seats. Seats must be firmly fixed.

6.7.4. Spare wheel

Spare wheels can be moved into cockpit, if they are safely fixed.

6.7.5. Towing eyes

Car must be equipped with towing eyes: Car must have at least one towing-eye in front and one in back side of car, and towing-eyes must be demonstratively marked. This towing-eye must be very firmly fixed to cars body if there is no frame, otherwise to frame. It will be clearly visible and painted in yellow, red or orange. Allowed to adjust original "hook" towing eye.

6.8. Electrical system

All wires and wire joints must be insulated.

Battery:

Type, capacity and cables for battery connections are not limited. Allowed to install not more than three batteries. Batteries must be safely fixed. In case the battery is located in cockpit it must be in hermetic partition and as obligatory is ventilation system ensuring ventilation system which can conduct steam out of battery partition, and it must lead to outside of car.

Lighting system:

Lighting elements are not limited, but must correspond country laws, the competition is taking place. Present lighting elements must be in working order in moment of technical commission.

Main electrical equipment switch:

Car must be equipped with main electrical equipments switch (battery, generator, lighting elements, alarm system, ignition, starter and other). It must work with out sparking and must be in reachable area for pilot and copilot. Turning off all electrical equipment must be followed by engine stop apart from it's type (diesel or petrol).

6.9.Fuel circuit.

Allowed to use original fuel tanks and to change them.

Fuel tank

Fuel tanks must be separated from cockpit with flame-proof material.

Forbidden to lead out fuel tank ventilation into cockpit.

Filling neck and cap must not be put out of car body. As fuel tank cap can be used every lock system which can provide accidental cap opening in case of hit or incomplete lock.

Fuel pipes:

Allowed to interchange, replace, move and reinforce fuel pipes, taking in account that in cockpit it must be in entire metallic piece. Any fuel pipe joints in cockpit are forbidden except pairs metal-metal, metal – homologued fuel pipe.

6.10 Jack

Hi-jacks, an jacking points are not limited.

Forbidden use of stationary adjusted, jacking systems of any type (mechanical, pneumatic, hydraulic and other).

Number of jacks is not limited.

6.11.Winch and additional equipment

Car must be equipped with at least one winch (one not manual winch), traction parameters must exceed car weight at least 1,4 times. Allowed to use winch of any type.

Allowed wheel spools.

To ensure car safety it must be equipped with rope dampener.

To avoid tree damaging during winch usage, car must be equipped with flat, corrosion-resistant sling (minimal wide 50 mm).

Winch rope, rope extenders, sling, fixing hooks, rope loop, blocks for usage with winch must stand load at least two times more than maximal winch power.

Winch rope, rope extenders, sling, fixing hooks, rope loop, blocks, dampener must be safely fixed during car movement.

#### 6.12.Safety cage.

It is allowed to adjust interior and exterior safety cage. Cars must be equipped with main safety rollbar. Construction of main safety rollbar can be seen in attachment No. 2, or is factory produced. All parameters and ways of making main safety rollbar must correspond attachment No. 2 or be homologued.

Cars having original metallic roof must have steel safety frame over crew heads with at least four fixing points to car frame.

Cars not having metallic roof must have steel safety cage, consisting main rollbar and front rollbar and at least 6 fixing points to frame.

Recommended to use FIA certificated cages.

#### 6.13.Safety belts.

Car must have at least three point car safety belts, factory produced, for all crew members. Third or side seat must be equipped with at least four point seat belt factory produced.

#### 6.14.Extinguisher

In car must be extinguisher, factory made, it must contain not less than 4 kg (2+2) extinguish structure (Freon-12, bromethylen, carbonic acid, extinguishing powder), concentrated in one or two bottles.

Usage of foam extinguisher is forbidden.

Extinguisher must be easily reachable for pilot and co-pilot. It must be safely fixed, and must ensure quick and easy removal without using any tool. On bottle must be shown: net weight, extinguisher weight, and bottle weight.

### 7. Additional equipment

Additional equipment must be as given in attachment No.1.

#### **Obligatory additional devices**

##### **1. First aid kit.**

Car has to be fitted with special first aid kit. All kit components must be with legal period of use and with no visible damage of wrapping. First aid kit must be in easy reachable place, and have waterproof package. In first aid kit must be:

##### **2. Communications**

To ensure safety, and temporary medical assistance, it is **recommended** to equip car with radio station MW-diapason (27 MHz ). As intermedia can be used any radio station using other diapason, radio, cellular and satellite phones.



**Safety cage.**

**Attachment No. 2**

**Safety cage – safety rollbar for TR1 and TR2**

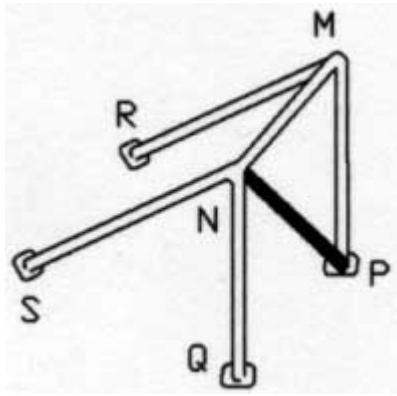

Material	Minimum tensile strength	Minimum dimensions (mm)	Use
Cold drawn seamless unalloyed carbon steel containing a maximum of 0.22% of carbon	350 N/mm <sup>2</sup>	45(1,75'')x2,5 or 50(2,0'')x2,0	Main rollbar

**Safety cage TR 2 with 3 passenger place and TR3**

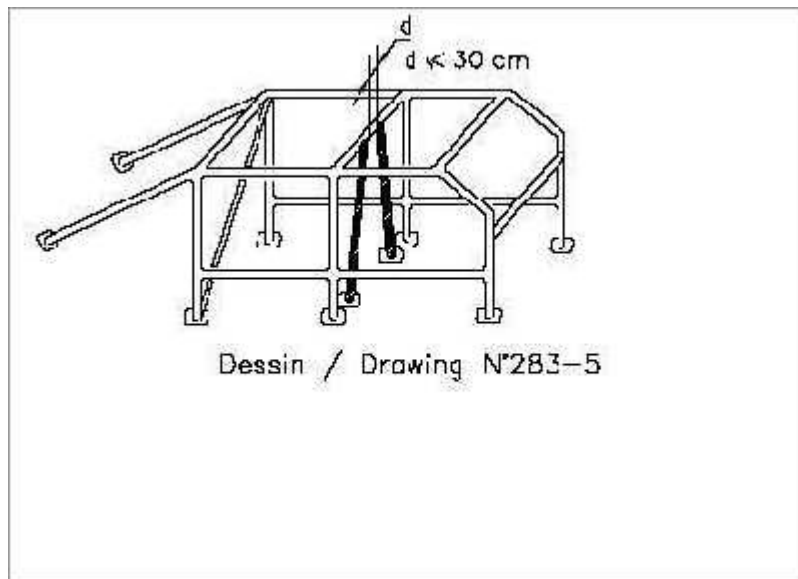

Принято и утверждено 4 декабря 2004 г. между странами и организаторами “Кубка Балтии 2005 -2008”. Пописи: J. Lazdans – LV “Mazozoli”; M. Mumme – EE EAF, A. Sutkus – LT LVKA, V. Marozov – EE EORK; A. Myllyla – FIN Lapland 4Wheel drive Club.



4x4 NEZ CUP  
TROPHY 2011

### ENTRY FORM / PIETEIKUMA FORMA

CAR No. / STARTA Nr.		CLASS/ KATEGORIJA (TR1/TR2/TR3/OPEN)	
		Nepieciešama nr. Uzlīme	
DATE / DATUMS			
ENTRANT NAME / PIETEICĒJS		PERSONAL CODE / PERSONAS KODS	
ADDRESS /ADRESE		TELEPHONES /TELEFONI	
		E-MAIL /E-PASTS	
I, entrant, here signed assure that all the information in the entry form is true / .Es, pieteicējs šeit parakstījes apliecinu, ka visa pieteikuma formā sniegtā informācija ir patiesa			
VEHICLE / AUTOMAŠĪNA			
MAKE MARKA		FIA technical passport TEHNISKĀS PASES Nr.	
MODEL MODELIS		YEAR OF MANUFACTURING IZLAIDUMA GADS	
		REGISTRATION Nr. REĢISTRĀCIJAS Nr.	

DRIVER /PILOTS	CO-DRIVER /STŪRMANIS
SURNAME /UZVĀRDS	SURNAME /UZVĀRDS
FIRST NAME /VĀRDS	FIRST NAME /VĀRDS
PERSONAL CODE / PERSONAS KODS	PERSONAL CODE / PERSONAS KODS
ADDRESS /Adrese	ADDRESS /Adrese
COUNTRY /VALSTS	COUNTRY /VALSTS
TELEPHONES /TELEFONI	TELEPHONES /TELEFONI
E-MAIL / E-PASTS	E-MAIL / E-PASTS
DRIVING LICENCE Nr VADĪTĀJA APLIECĪBAS Nr.	DRIVING LICENCE Nr VADĪTĀJA APLIECĪBAS Nr.
COMPETITOR LICENCE Nr/ LICENCES Nr	COMPETITOR LICENCE Nr/ LICENCES Nr
INSURANCE POLICY No /APDROŠINĀŠANAS POLISES Nr.	INSURANCE POLICY No /APDROŠINĀŠANAS POLISES Nr.
Insurance policy expires/ Apdrošināšanas polise derīga līdz	Insurance policy expires/ Apdrošināšanas polise derīga līdz
Visas personas, kas atrodas automašīnā apņemties pasākuma laikā ievērot Latvijā spēkā esošos CSN un uzņemas pilnu atbildību par savu darbību vai bezdarbību. kā arī atsakās no visām pretenzijām pret organizatoru un LAF oficiālajām personām. Apliecinu, ka pieteikumā minētā informācija ir pareiza.	
All persons who are in vehicle during the competition assure that they will follow Road traffic rules in force in theritory of LATVIA and and takes all the risk for their action or inaction and renounce in advance all responsibility on the part of the organizers, its officials the Latvian Automobile Federation. I assure information included in entry form is true."	

SIGNATURE/ PARAKSTS \_\_\_\_\_

SIGNATURE/ PARAKSTS \_\_\_\_\_

2 CO-DRIVER /2 STŪRMANIS	3 CO-DRIVER /3 STŪRMANIS
SURNAME /UZVĀRDS	SURNAME /UZVĀRDS
FIRST NAME /VĀRDS	FIRST NAME /VĀRDS
PERSONAL CODE / PERSONAS KODS	PERSONAL CODE / PERSONAS KODS
ADDRESS /Adrese	ADDRESS /Adrese
COUNTRY /VALSTS	COUNTRY /VALSTS
TELEPHONES /TELEFONI	TELEPHONES /TELEFONI
E-MAIL / E-PASTS	E-MAIL / E-PASTS
DRIVING LICENCE Nr VADĪTĀJA APLIECĪBAS Nr.	DRIVING LICENCE Nr VADĪTĀJA APLIECĪBAS Nr.
COMPETITOR LICENCE Nr/ LICENCES Nr	COMPETITOR LICENCE Nr/ LICENCES Nr
INSURANCE POLICY No /APDROŠINĀŠANAS POLISES Nr.	INSURANCE POLICY No /APDROŠINĀŠANAS POLISES Nr.
Insurance policy expires/ Apdrošināšanas polise derīga līdz	Insurance policy expires/ Apdrošināšanas polise derīga līdz
Visas personas, kas atrodas automašīnā apņemties pasākuma laikā ievērot Latvijā spēkā esošos CSN un uzņemas pilnu atbildību par savu darbību vai bezdarbību. kā arī atsakās no visām pretenzijām pret organizatoru un LAF oficiālajām personām. Apliecinu, ka pieteikumā minētā informācija ir pareiza.	
All persons who are in vehicle during the competition assure that they will follow Road traffic rules in force in theritory of LATVIA and and takes all the risk for their action or inaction and renounce in advance all responsibility on the part of the organizers, its officials the Latvian Automobile Federation. I assure information included in entry form is true."	

SIGNATURE/ PARAKSTS \_\_\_\_\_

SIGNATURE/ PARAKSTS \_\_\_\_\_