

**Safety cage.**

**Attachment No. 2**

**Safety cage – safety rollbar for TR1 and TR2**

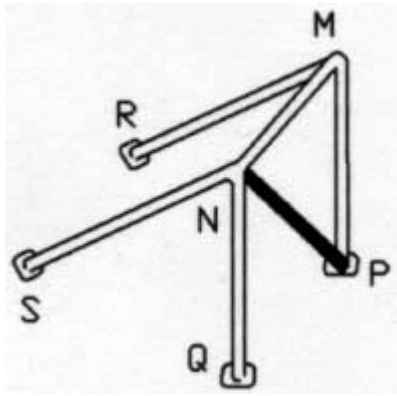

Material	Minimum tensile strength	Minimum dimensions (mm)	Use
Cold drawn seamless unalloyed carbon steel containing a maximum of 0.22% of carbon	350 N/mm <sup>2</sup>	45(1,75'')x2,5 or 50(2,0'')x2,0	Main rollbar

**Safety cage TR 2 with 3 passenger place and TR3**

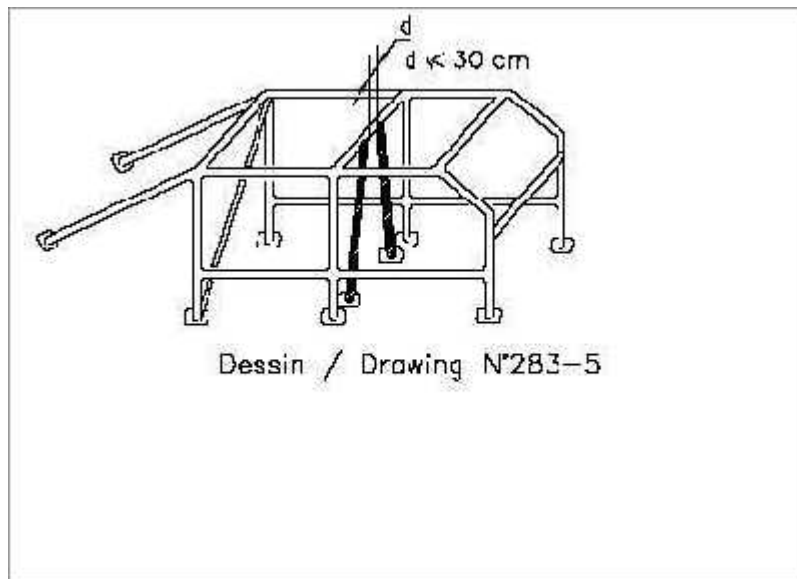

Принято и утверждено 4 декабря 2004 г. между странами и организаторами “Кубка Балтии 2005 -2008”. Пописи: J. Lazdans – LV “Mazozoli”; M. Mumme – EE EAF, A. Sutkus – LT LVKA, V. Marozov – EE EORK; A. Myllyla – FIN Lapland 4Wheel drive Club.